

4SIE
Sh SSh VSh DSh FLAI
REG CSP SEMb EMD
3SIE



mehr als nur Motor
Qualität in der Antriebstechnik

plus qu'un moteur

La Qualité en technique d'entraînement



Ökonomie und Ökologie

Energieeffizienz mit Know-how von Cantoni. Die Energiesparmotoren von Cantoni basieren auf modernsten Magnetwerkstoffen, einer speziellen Wicklungsauslegung und einer optimierten Lagerung und Belüftung.

Sie entsprechen in Leistungsanzuordnung und Anbauabmessungen den bisherigen Standardmotoren, sodass bereits in Betrieb befindliche Anlagen umgerüstet und ältere Motoren problemlos durch sparsame Antriebe ersetzt werden können.

Économie et écologie

Les moteurs à économie d'énergie de chez Cantoni sont basés sur des matériaux magnétiques de pointe, un design d'enroulement spécial, des paliers à roulement optimisés et une ventilation performante.

Ils correspondent aux critères de performances et aux dimensions de montage des gammes de moteurs standards précédent, déjà en fonction.



Hoch effiziente Energiesparmotoren

- Senken den Stromverbrauch
- Helfen, Energiekosten zu sparen
- Entsprechen den gesetzlichen Vorschriften in der Europäischen Union
- Eignen sich zur Umrüstung älterer Anlagen
- Schonen Naturressourcen durch hohe Energieeffizienz.
- Die Motoren der Cantoni-Energiesparreihe Typ 3SIE / 3SIEz / 3SIEK / 3SIEL und 4SIE / 4SIEz / 4SIEK / 4SIEL... entsprechen mit ihren Wirkungsgraden der Wirkungsgradklasse **IE3** und **IE4** nach IEC/EN 60034-2-1.

Moteurs à économie d'énergie hautement efficace

- Consommation d'énergie réduite
- Favorise à réduire les coûts d'énergie
- Conforme aux exigences légales dans l'union européenne
- Compatible avec les anciennes installations
- Respect des ressources naturelles grâce à une efficacité énergétique élevée
- Les moteurs de la gamme d'économie d'énergie Cantoni type : 3SIE / 3SIEz / 3SIEK / 3SIEL / et 4 SIE / 4 SIEz / 4SIEK / 4 SIEL... correspondent à leur classe d'efficacité des normes **IE3** et **IE4**, tous conforme à la directive IEC60034-2-1

Energiesparmotoren Premium Efficiency **IE3** und Super Premium Efficiency **IE4** sind universell einsetzbar. Ihre Vorzüge spielen sie vor allem im allgemeinen Maschinenbau aus sowie überall dort, wo hohe Betriebsstunden anfallen.

Fox Drive Standardserie ist unsere eigene Ausführung mit hoher Qualität. Dank grosser Stückzahlen können wir Ihnen ein attraktives Preis-Leistungs-Verhältnis anbieten. **Qualität zum Bestpreis.**

Für **IE3 & IE4** Motoren gewähren wir Ihnen eine Garantie von **3 Jahren**. Nutzungsbedingungen finden Sie unter www.fox-drive.ch

Les moteurs à économie d'énergie Premium Efficiency **IE3** et Super Premium Efficiency **IE4** sont universellement applicables. Leurs avantages sont principalement utilisés dans la construction mécanique générale ainsi que partout où des heures de fonctionnement élevées sont nécessaires.

Fox Drive Standard Series est notre propre version de haute qualité. Grâce à de grandes quantités, nous pouvons vous offrir un rapport qualité-prix attractif. **La qualité au meilleur prix**

Pour les moteurs **IE3 et IE4**, nous vous donnons une garantie de **3 ans**. Les conditions d'utilisation peuvent être trouvées sur www.fox-drive.ch

Inhaltsverzeichnis Table des matières

Seite Page	Produkte	Produits	Seite Page	Produkte	Produits
2	2 Pol 2800min.-1	2 pôles 2800min.-1	11	1Ph. 2 Pol 2800min.-1	Monoph. 2 pôles 2800min.-1
3	4 Pol 1400min.-1	4 pôles 1400min.-1	12	1Ph. 4 Pol 1400min.-1	Monoph. 4 pôles 1400min.-1
4	6 Pol 900min.-1	6 pôles 900min.-1	13	Fremdlüfter / Regenschutzd.	Vent. forcées / capot de pluie
5	8 Pol 700min.-1	8 pôles 700min.-1	14	Ersatzteile IEC 56 - 80	pièces de rechange IEC 56 - 80
6	IE4 - Motoren	Moteurs IE4	15	Ersatzteile IEC 90 - 180	pièces de rechange IEC 90 - 180
7	6/4 Pol 900/1400min.-1	6/4 pôles 900/1400min.-1	16	Ersatzteile IEC 200 - 315	pièces de rechange IEC 200 - 315
8	6/4 Pol 900/1400min.-1	6/4 pôles 900/1400min.-1	17	Gehäuse der Motoren	Carcasse moteurs
9	4/2 Pol 1400/2800min.-1	4/2 pôles 1400/2800min.-1	18	Wellenbelastung	Charge arbre moteurs
10	8/4 Pol 700/1400min.-1	8/4 pôles 700/1400min.-1	19	Masse	Dimensions
			20	Lager / Einbaulagen	Roulements / Formes de montage

3Ph Asynchron-Motoren

- 3Ph Motoren nach IEC 60034-30
- Wirkungsgrad nach IEC 60034-30-1
- Weitbereichspannung 400 Volt +/- 10 %, 50/60 Hz
- Schutzart IP55 • Isolationsklasse „F“ • Betriebsart S1
- Ausgerüstet mit PTC - Kaltleiter 1Stk. pro Phase ab IE3
- Typ: Shz / 3SIEz = Variable Klemmenkastenposition "Multifuss"

Moteurs asynchrones triphasés

- Moteurs conformes à la directive IEC 60034-30
- Rendement conforme à la directive IEC 60034-30-1
- Large plage de tension 400 Volt +/- 10 %, 50/60 Hz
- Protection IP55 • Classe d'isolation F • Service continu S1
- Equipé avec des thermistors PTC une pièce par phase / moteurs IE3
- Typ: Shz/3SIEz= Position boîte à bornes variable "multiplied"

SH

Artikel N° (B3)	Typ H				P _N kW	T _N (Nm)	I _N A 400V	η _N %			cos.	n _N min.-1	Volt	kg	CHF
	Sh	56	A	2				50%	75%	100%					
1001	Sh	56	A	2	0.09	0.31	0.35	45.0	52.0	62.0	0.63	2820	230/400	2.9	128.50
1030	Sh	56	B	2	0.12	0.41	0.38	50.0	58.0	65.0	0.70	2800	230/400	3.2	135.85
24000	PSh	56	XC	2	0.18	0.61	0.70	57.0	66.0	66.0	0.60	2840	230/400	3.7	185.85
1060	Sh	63	A	2	0.18	0.62	0.50	63.0	68.0	70.0	0.77	2760	230/400	3.5	144.60
1090	Sh	63	B	2	0.25	0.86	0.65	66.0	69.0	72.0	0.78	2780	230/400	4.1	158.75
24030	PSh	63	XC	2	0.37	1.27	1.00	69.0	74.0	75.0	0.72	2820	230/400	5.0	212.75
1120	Sh	71	A	2	0.37	1.26	1.00	67.0	69.0	71.0	0.77	2800	230/400	5.0	167.60
1150	Sh	71	B	2	0.55	1.88	1.35	69.0	72.0	75.0	0.82	2790	230/400	6.0	188.15

3SIE

PE21180	3SIEz	80	A	2	0.75	2.51	1.7	79.0	82.0	82.0	0.82	2850	230/400	10.6	333.15
PE21217	3SIEz	80	B	2	1.1	3.7	2.2	82.0	83.0	83.0	0.86	2840	230/400	11.9	374.00
PE21254	3SIEz	90	S	2	1.5	5.0	3.0	82.7	84.5	84.2	0.85	2925	230/400	16.5	361.10
PE21291	3SIEz	90	L	2	2.2	7.3	4.3	85.4	85.8	85.9	0.86	2910	230/400	18.5	428.10
PE21328	3SIEz	100	L	2	3.0	9.8	5.8	86.2	87.7	87.1	0.85	2915	400/690	25.0	525.10
PE21365	3SIEz	112	M	2	4.0	13.0	7.4	88.1	88.0	88.1	0.89	2925	400/690	35.5	716.65
PE24170	P3SIEz	112	MA	2	5.5	18.0	10.2	89.1	89.0	89.2	0.87	2925	400/690	39.5	892.50
PE24200	P3SIE	112	MB	2	7.5	24.4	13.8	90.1	90.0	90.1	0.87	2930	400/690	49.1	1'037.40
PE21402.z	3SIEz	132	SA	2	5.5	17.9	10.0	87.7	89.2	89.2	0.89	2940	400/690	55.0	953.00
PE21439.z	3SIEz	132	SB	2	7.5	24.4	13.3	89.0	90.3	90.1	0.90	2940	400/690	64.0	1'107.75
PE24230.z	P3SIEz	132	M	2	9.2	29.9	16.6	89.9	91.1	90.7	0.88	2935	400/690	93.0	1'572.15
PE24260.z	P3SIEz	132	MA	2	11	35.9	19.6	91.4	91.7	91.2	0.89	2925	400/690	96.0	1'710.55
PE21476.z	3SIEz	160	MA	2	11	35.7	19.2	89.7	91.0	91.2	0.90	2945	400/690	123	1'619.20
PE21513.z	3SIEz	160	MB	2	15	48.6	26.2	89.8	91.9	91.9	0.90	2945	400/690	132	2'046.85
PE21550.z	3SIEz	160	L	2	18.5	60.1	32.1	92.2	92.8	92.4	0.90	2940	400/690	139	2'403.15
PE24290.z	P3SIEz	160	LA	2	22	71.2	38.5	91.9	92.8	92.7	0.89	2950	400/690	148	2'759.20
PE21587.z	3SIEz	180	M	2	22	71.1	38.1	92.1	92.9	92.7	0.90	2955	400/690	190	3'008.05
PE21620	3SIE	200	LA	2	30	97.0	51	93.1	93.7	93.5	0.90	2965	400/690	275	4'159.25
PE21653	3SIE	200	LB	2	37	120	63	93.5	93.8	93.7	0.90	2955	400/690	295	4'604.65
PE21686	3SIE	225	M	2	45	145	78	94.2	94.6	94.2	0.88	2972	400/690	385	5'521.45
PE21719	3SIE	250	M	2	55	177	92	94.5	94.8	94.5	0.91	2969	400/690	495	6'381.25
PE21752	3SIE	280	S	2	75	241	126	94.2	94.8	94.7	0.91	2978	400/690	660	8'256.35
PE21785	3SIE	280	M	2	90	289	150	94.5	95.1	95.0	0.91	2979	400/690	690	9'328.50
PE21818	3SIE	315	S	2	110	353	181	95.4	95.6	95.2	0.92	2978	400/690	865	10'493.90
PE21851	3SIE	315	MA	2	132	423	217	95.8	95.9	95.6	0.92	2977	400/690	970	13'358.30
PE21884	3SIE	315	MB	2	160	513	262	95.9	96.1	95.8	0.92	2978	400/690	1118	14'684.25
PE21888	3SIE	315	MC	2	200	641	324	95.9	96.1	95.8	0.93	2980	400/690	1185	a.A.

- Zuschläge auf Basisausführung B3 / • Supplément de prix pour la forme B3
- IEC 56-112** - B5; B14-1; B14-2 **+7%**; **IEC 56-112** - B3B5; B3B14-1; B3B14-2 **+9%**;
- IEC 132-315** B5; B14-1; B14-2 **+5%**; **IEC 132-315** - B3B5; B3B14-1; B3B14-2 **+7%**;

3Ph Asynchron-Motoren

- 3Ph Motoren nach IEC 60034-30
- Wirkungsgrad nach IEC 60034-30-1
- Weitbereichsspannung 400 Volt +/- 10 %, 50/60 Hz
- Schutzart IP55 • Isolationsklasse „F“ • Betriebsart S1
- Ausgerüstet mit PTC - Kaltleiter 1Stk. pro Phase ab IE3
- Typ: Shz / 3SIEz = Variable Klemmenkastenposition "Multifuss"

Moteurs asynchrones triphasés

- Moteurs conformes à la directive IEC 60034-30
- Rendement conforme à la directive IEC 60034-30-1
- Large plage de tension 400 Volt +/- 10 %, 50/60 Hz
- Protection IP55 • Classe d'isolation F • Service continu S1
- Equipé avec des thermistors PTC une pièce par phase / moteurs IE3
- Typ: Shz/3SIEz= Position boîte à bornes variable "multiplied"

SH

Artikel N° (B3)	Typ				P _N kW	T _N (Nm)	I _N A 400V	η _N %			cos.	n _N min.-1	Volt	kg	CHF
	H							50%	75%	100%					
2000	Sh	56	A	4	0.06	0.41	0.30	40.0	48.0	50.0	0.58	1400	230/400	2.6	128.50
2030	Sh	56	B	4	0.09	0.61	0.40	54.0	58.0	58.0	0.60	1400	230/400	2.8	135.85
24350	PSh	56	XC	4	0.12	0.82	0.70	43.0	53.0	52.0	0.55	1400	230/400	3.3	187.55
2060	Sh	63	A	4	0.12	0.83	0.45	56.0	60.0	60.0	0.63	1380	230/400	3.5	144.60
2090	Sh	63	B	4	0.18	1.52	0.70	52.0	55.0	57.0	0.66	1380	230/400	4.1	158.75
24380	PSh	63	XC	4	0.25	1.70	1.00	59.0	66.0	65.0	0.55	1380	230/400	5.0	203.70
2120	Sh	71	A	4	0.25	1.73	0.85	60.0	63.0	66.0	0.64	1380	230/400	5.1	162.55
2150	Sh	71	B	4	0.37	2.59	1.25	64.0	67.0	70.0	0.68	1370	230/400	5.8	185.00
24410	PSh	71	XC	4	0.55	3.86	2.00	63.0	69.0	70.0	0.62	1360	230/400	7.2	257.05
2180	Shz	80	A	4	0.55	3.75	1.60	70.0	69.0	73.0	0.69	1400	230/400	7.5	217.05

3SIE

PE21917	3SIEz	80	B	4	0.75	5.0	2.1	81.5	82.0	82.5	0.64	1430	230/400	11.0	362.80
PE21954	3SIEz	90	S	4	1.1	7.3	2.5	81.8	84.0	84.1	0.77	1450	230/400	18.0	399.00
PE21991	3SIEz	90	L	4	1.5	9.9	3.3	83.9	85.5	85.3	0.78	1450	230/400	21.0	434.80
PE22028	3SIEz	100	LA	4	2.2	14.4	4.6	85.0	86.8	86.7	0.79	1460	230/400	27.5	557.15
PE22065	3SIEz	100	LB	4	3.0	19.8	6.4	85.8	88.7	87.7	0.77	1460	400/690	31.0	649.10
PE22102	3SIEz	112	M	4	4.0	26.2	8.4	88.5	89.0	88.6	0.88	1460	400/690	41.5	866.80
PE24530	P3SIE	112	MA	4	5.5	36.0	11.1	89.0	89.2	89.6	0.80	1460	400/690	54.0	929.25
PE22139.z	3SIEz	132	S	4	5.5	35.7	10.4	88.6	89.8	89.6	0.85	1465	400/690	73.5	1'052.20
PE22176.z	3SIEz	132	M	4	7.5	49.1	14.4	89.7	90.6	90.4	0.83	1465	400/690	82.0	1'273.00
PE24560.z	P3SIEz	132	MA	4	9.2	60.2	17.6	91.0	91.5	91.0	0.83	1460	400/690	93.0	1'771.75
PE2438.z	P3SIEz	132	MB	4	11	72.0	20.9	91.5	92.0	91.4	0.83	1460	400/690	97.0	1'876.55
PE22213.z	3SIEz	160	M	4	11	71.5	20.9	89.8	91.3	91.4	0.83	1475	400/690	127	1'831.40
PE22250.z	3SIEz	160	L	4	15	97.1	28.3	90.8	92.1	92.1	0.83	1475	400/690	135	2'325.55
PE22287.z	3SIEz	180	M	4	18.5	120.2	33.9	92.1	92.8	92.6	0.85	1480	400/690	190	2'883.30
PE22320.z	3SIEz	180	L	4	22	142.4	41.1	91.4	92.8	93.0	0.83	1475	400/690	200	3'314.55
PE22353	3SIE	200	L	4	30	194	52	94.2	94.3	93.8	0.89	1477	400/690	329	4'185.20
PE22386	3SIE	225	S	4	37	238	65	94.1	94.4	94.0	0.87	1485	400/690	373	4'843.00
PE22419	3SIE	225	M	4	45	290	78	94.4	94.8	94.3	0.88	1483	400/690	410	6'013.65
PE22452	3SIE	250	M	4	55	353	93	94.0	94.8	94.7	0.90	1487	400/690	520	7'137.50
PE22485	3SIE	280	S	4	75	481	125	93.9	95.0	95.0	0.91	1488	400/690	710	9'230.05
PE22518	3SIE	280	M	4	90	576	153	94.9	95.5	95.4	0.89	1491	400/690	761	9'841.25
PE22551	3SIE	315	S	4	110	706	185	95.1	95.5	95.4	0.90	1488	400/690	920	10'783.90
PE22584	3SIE	315	MA	4	132	847	219	95.6	95.9	95.6	0.91	1489	400/690	1030	11'825.10
PE22617	3SIE	315	MB	4	160	1026	268	95.9	96.1	95.8	0.90	1490	400/690	1130	12'752.15
PE22621	3SIE	315	MC	4	200	1284	333	95.8	96.2	96.2	0.90	1488	400/690	1205	18'366.60

- Zuschläge auf Basisausführung B3 / • Supplément de prix pour la forme B3
- IEC 56-112** - B5; B14-1; B14-2 **+7%**; **IEC 56-112** - B3B5; B3B14-1; B3B14-2 **+9%**;
- IEC 132-315** B5; B14-1; B14-2 **+5%**; **IEC 132-315** - B3B5; B3B14-1; B3B14-2 **+7%**;

3Ph Asynchron-Motoren

- 3Ph Motoren nach IEC 60034-30
- Wirkungsgrad nach IEC 60034-30-1
- Weitbereichspannung 400 Volt +/- 10 %, 50/60 Hz
- Schutzart IP55 • Isolationsklasse „F“ • Betriebsart S1
- Ausgerüstet mit PTC - Kaltleiter 1Stk. pro Phase ab IE3
- Typ: Shz / 3SIEz = Variable Klemmenkastenposition "Multifuss"

Moteurs asynchrones triphasés

- Moteurs conformes à la directive IEC 60034-30
- Rendement conforme à la directive IEC 60034-30-1
- Large plage de tension 400 Volt +/- 10 %, 50/60 Hz
- Protection IP55 • Classe d'isolation F • Service continu S1
- Equipé avec des thermistors PTC une pièce par phase / moteurs IE3
- Typ: Shz/3SIEz= Position boîte à bornes variable "multiplied"

SH

Artikel N° (B3)	Typ H				P _N kW	T _N (Nm)	I _N A 400V	η _N %			cos.	n _N min.-1	Volt	kg	CHF
								50%	75%	100%					
3030	Sh	63	A	6	0.09	1.05	0.45	26.0	32.0	40.0	0.75	820	230/400	3.5	223.15
3060	Sh	63	B	6	0.12	1.30	0.65	38.0	44.0	50.0	0.65	870	230/400	4.1	230.50
3070	PSh	63	XC	6	0.15	1.65	1.00	37.0	43.0	45.0	0.55	870	230/400	4.8	283.90
3090	Sh	71	A	6	0.18	1.93	0.75	47.0	54.0	57.0	0.68	890	230/400	4.8	181.25
3120	Sh	71	B	6	0.25	2.78	1.00	45.0	52.0	55.0	0.79	860	230/400	5.6	199.20
3135	PSh	71	XC	6	0.37	4.02	1.35	50.0	58.0	60.0	0.70	880	230/400	7.3	239.40
3150	Shz	80	A	6	0.37	3.88	1.40	61.0	63.0	64.0	0.65	910	230/400	7.4	222.10
3180	Shz	80	B	6	0.55	5.84	1.80	62.0	65.0	67.0	0.70	900	230/400	8.7	259.75

3SIE

PE22683	3SIEz	90	S	6	0.75	7.6	1.9	77.2	79.3	78.9	0.71	940	230/400	16.0	390.80
PE22720	3SIEz	90	L	6	1.1	11.1	2.8	79.9	81.9	81.0	0.70	940	230/400	19.0	429.25
PE22757	3SIEz	100	L	6	1.5	14.9	3.5	81.1	82.8	82.5	0.74	960	230/400	23.5	534.55
PE22794	3SIEz	112	M	6	2.2	21.8	5.0	83.9	84.9	84.3	0.76	960	230/400	34.0	698.35
PE22831 z	3SIEz	132	S	6	3.0	29.7	6.1	85.0	87.2	87.0	0.81	965	400/690	54.0	850.00
PE22868 z	3SIEz	132	MA	6	4.0	39.8	8.1	89.1	89.2	88.0	0.81	965	400/690	72.0	1'002.95
PE22905 z	3SIEz	132	MB	6	5.5	54.7	11.1	88.9	89.1	88.0	0.81	960	400/690	80.0	1'233.65
PE22915 z	3SIEz	132	MC	6	7.5	74.2	16.0	88.4	89.5	89.1	0.76	965	400/690	82.0	1'760.75
PE22942 z	3SIEz	160	M	6	7.5	73.8	14.8	89.0	89.9	89.5	0.82	970	400/690	134	1'779.75
PE22979 z	3SIEz	160	L	6	11	108	21.4	89.6	90.5	90.3	0.82	970	400/690	146	2'334.35
PE23016 z	3SIEz	180	L	6	15	146	29.3	90.0	91.3	91.2	0.81	980	400/690	198	3'191.60
PE23049	3SIEz	200	LA	6	18.5	179	36.0	91.3	92.0	91.7	0.81	988	400/690	285	4'076.40
PE23082	3SIE	200	LB	6	22	213	42.0	91.7	92.2	92.2	0.82	987	400/690	309	4'304.35
PE23115	3SIE	225	M	6	30	290	55.0	92.3	92.9	92.9	0.83	989	400/690	392	5'293.70
PE23148	3SIE	250	M	6	37	357	70.0	92.2	93.4	93.3	0.82	991	400/690	440	6'365.95
PE23181	3SIE	280	S	6	45	433	86.0	92.9	93.8	93.7	0.81	993	400/690	635	7'930.15
PE23214	3SIE	280	M	6	55	529	103	93.8	94.4	94.1	0.82	992	400/690	695	8'670.70
PE23247	3SIE	315	S	6	75	722	139	94.6	95.0	94.7	0.82	992	400/690	900	12'571.00
PE23280	3SIE	315	MA	6	90	866	167	95.1	95.4	95.1	0.82	993	400/690	965	13'834.70
PE23313	3SIE	315	MB	6	110	1059	203	95.2	95.6	95.2	0.82	992	400/690	1110	15'692.00
PE23320	3SIE	315	MC	6	132	1271	241	95.4	95.8	95.4	0.83	992	400/690	1230	22'443.75
PE23330	3SIE	315	MD	6	160	1540	310	95.2	95.7	95.6	0.78	992	400/690	1235	23'086.00

- Zuschläge auf Basisausführung B3 / • Supplément de prix pour la forme B3
- IEC 63-112** - B5; B14-1; B14-2 **+7%**; **IEC 63-112** - B3B5; B3B14-1; B3B14-2 **+9%**;
- IEC 132-315** B5; B14-1; B14-2 **+5%**; **IEC 132-315** - B3B5; B3B14-1; B3B14-2 **+7%**;

3Ph Asynchron-Motoren

- 3Ph Motoren nach IEC 60034-30
- Wirkungsgrad nach IEC 60034-30-1
- Weitbereichsspannung 400 Volt +/- 10 %, 50/60 Hz
- Schutzart IP55 • Isolationsklasse „F“ • Betriebsart S1
- Ausgerüstet mit PTC - Kaltleiter 1Stk. pro Phase ab S1E
- Typ: Shz = Variable Klemmenkastenposition "Multifuss"

Moteurs asynchrones triphasés

- Moteurs conformes à la directive IEC 60034-30
- Rendement conforme à la directive IEC 60034-30-1
- Large plage de tension 400 Volt +/- 10 %, 50/60 Hz
- Protection IP55 • Classe d'isolation F • Service continu S1
- Equipé avec des thermistors PTC une pièce par phase / moteurs S1E
- Typ: Shz = Position boîte à bornes variable "multiplied"

SH

Artikel N° (B3)	Typ H				P _N kW	T _N (Nm)	I _N A 400V	η _N %			cos.	n _N min.-1	Volt	kg	CHF
	Sh							50%	75%	100%					
4000	Sh	63	A	8	0.04	0.57	0.35	20.0	31.0	35.0	0.56	670	230/400	3.5	176.20
4030	Sh	63	B	8	0.06	0.87	0.50	20.0	31.0	35.0	0.48	660	230/400	4.1	182.80
4060	Sh	71	A	8	0.09	1.26	0.75	25.0	31.0	35.0	0.50	680	230/400	4.9	206.00
4090	Sh	71	B	8	0.12	1.71	0.70	40.0	45.0	47.0	0.63	670	230/400	5.8	223.95
4110	PSh	71	XC	8	0.18	2.53	1.40	40.0	44.0	45.0	0.52	680	230/400	7.3	313.95
4120	Shz	80	A	8	0.18	2.53	0.90	43.0	51.0	53.0	0.57	680	230/400	7.5	244.15
4150	Shz	80	B	8	0.25	3.51	1.20	52.0	55.0	57.0	0.60	680	230/400	8.9	282.75
4170	PShz	80	XC	8	0.37	5.20	1.70	51.0	54.0	58.0	0.60	680	230/400	11.0	441.40
4180	Shz	90	S	8	0.37	5.10	1.40	54.2	60.8	63.4	0.59	695	230/400	13.4	325.00
4210	Shz	90	L	8	0.55	7.80	1.90	60.4	65.3	65.0	0.64	675	230/400	15.3	378.55
4240	Shz	100	LA	8	0.75	10.1	2.30	65.9	70.5	71.1	0.66	710	230/400	23.6	405.60
4270	Shz	100	LB	8	1.1	14.9	3.40	67.6	71.8	72.2	0.65	705	230/400	26.3	521.75
4300	Shz	112	M	8	1.5	19.9	4.00	72.5	76.2	76.8	0.71	720	230/400	31.0	614.80
4330	Sh	132	S	8	2.2	29.6	5.50	75.4	78.2	78.0	0.74	710	230/400	53.0	841.05
4360	Sh	132	M	8	3.0	40.4	7.30	78.5	80.7	80.0	0.74	710	230/400	65.0	996.35
4390	Sh	160	MA	8	4.0	54.2	9.30	81.5	82.7	81.5	0.76	705	400/690	85.0	1'353.75
4394	Sh	160	MB	8	5.5	74.0	12.8	82.1	83.7	83.0	0.75	710	400/690	95.0	1'637.50
4420	Sh	160	L	8	7.5	102	16.4	84.5	85.5	84.5	0.78	705	400/690	115	1'994.25
4424	Sh	180	L	8	11	144	23.5	87.7	89.2	89.0	0.76	730	400/690	165	2'816.75

SIE

4450	SIE	200	L	8	15	195	29.1	88.8	90.0	89.5	0.83	733	400/690	255	3'356.95
4454	SIE	225	S	8	18.5	240	37.0	88.8	90.0	89.5	0.81	735	400/690	280	3'522.25
4480	SIE	225	M	8	22	286	44.0	90.0	90.8	90.4	0.80	735	400/690	315	3'873.45
4484	SIE	250	M	8	30	388	57.0	91.0	92.0	91.5	0.84	738	400/690	430	4'860.35
4510	SIE	280	S	8	37	479	69.0	92.0	93.1	92.8	0.83	737	400/690	535	6'556.50
4514	SIE	280	M	8	45	583	84.0	92.0	92.8	92.5	0.84	737	400/690	590	7'920.35
4540	SIE	315	S	8	55	715	106	92.0	93.0	92.7	0.81	735	400/690	720	9'629.05
4544	SIE	315	MA	8	75	972	142	92.5	93.5	93.2	0.82	737	400/690	750	10'263.75
4570	SIE	315	MB	8	90	1166	170	92.5	93.5	93.2	0.82	737	400/690	840	11'545.40
4574	SIE	315	MC	8	110	1425	215	92.3	93.1	93.3	0.79	737	400/690	1105	a.A.

- Zuschläge auf Basisausführung B3 / • Supplément de prix pour la forme B3
- IEC 63-112 - B5; B14-1; B14-2 +7%; IEC 63-112 - B3B5; B3B14-1; B3B14-2 +9%;
- IEC 132-315 B5; B14-1; B14-2 +5%; IEC 132-315 - B3B5; B3B14-1; B3B14-2 +7%;

3Ph Asynchron-Motoren

- 3Ph Motoren nach IEC 60034-30
- Wirkungsgrad nach IEC 60034-30-1
- Weitbereichsspannung 400 Volt +/- 10 %, 50/60 Hz
- Schutzart IP55 • Isolationsklasse „F“ • Betriebsart S1
- Ausgerüstet mit PTC - Kaltleiter 1Stk. pro Phase

Moteurs asynchrones triphasés

- Moteurs conformes à la directive IEC 60034-30
- Rendement conforme à la directive IEC 60034-30-1
- Large plage de tension 400 Volt +/- 10 %, 50/60 Hz
- Protection IP55 • Classe d'isolation F • Service continu S1
- Equipé avec des thermistors PTC une pièce par phase.

2Pol 2800 min.-1 - 2 pôles 2800 t/min.

Artikel N° (B3)	Typ H				P _N kW	T _N (Nm)	I _N A 400V	η _N %			cos.	n _N min.-1	Volt	kg	CHF
								50%	75%	100%					
SE21620	4SIE	200	LA	2	30	96	50	93.8	94.7	94.5	0.91	2970	400/690	287	5'199.00
SE21653	4SIE	200	LB	2	37	119	62	94.3	95.0	94.8	0.91	2971	400/690	307	5'756.00
SE21686	4SIE	225	M	2	45	144	77	93.2	94.5	95.0	0.89	2978	400/690	397	6'684.00
SE21719	4SIE	250	M	2	55	177	92	94.8	95.4	95.3	0.91	2972	400/690	507	7'977.00
SE21752	4SIE	280	S	2	75	240	127	94.8	95.5	95.6	0.89	2981	400/690	672	10'321.00
SE21785	4SIE	280	M	2	90	288	151	95.3	95.9	95.8	0.90	2981	400/690	702	11'662.00
SE21818	4SIE	315	S	2	110	352	184	95.8	96.2	96.0	0.90	2981	400/690	877	12'593.00
SE21851	4SIE	315	MA	2	132	423	218	96.2	96.2	96.2	0.91	2982	400/690	985	16'032.00
SE21884	4SIE	315	MB	2	160	512	264	95.7	96.3	96.3	0.91	2982	400/690	1148	17'623.00

4Pol 1400 min.-1 - 4 pôles 1400 t/min.

Artikel N° (B3)	Typ H				P _N kW	T _N (Nm)	I _N A 400V	η _N %			cos.	n _N min.-1	Volt	kg	CHF
								50%	75%	100%					
SE22353	4SIE	200	L	4	30	193	50	94.8	95.2	94.9	0.91	1483	400/690	341	5'231.00
SE22386	4SIE	225	S	4	37	238	65	94.9	95.6	95.2	0.86	1487	400/690	385	6'054.00
SE22419	4SIE	225	M	4	45	289	78	95.2	95.8	95.4	0.87	1487	400/690	422	7'517.00
SE22452	4SIE	250	M	4	55	353	92	95.1	95.8	95.7	0.90	1488	400/690	535	8'922.00
SE22485	4SIE	280	S	4	75	481	130	95.9	96.2	96.0	0.87	1489	400/690	728	11'538.00
SE22518	4SIE	280	M	4	90	577	155	96.1	96.4	96.1	0.87	1489	400/690	772	12'302.00
SE22551	4SIE	315	S	4	110	706	192	96.0	96.4	96.3	0.86	1489	400/690	932	12'941.00
SE22584	4SIE	315	MA	4	132	846	227	96.2	96.6	96.4	0.87	1490	400/690	1048	14'191.00
SE22617	4SIE	315	MB	4	160	1026	275	96.5	96.8	96.6	0.87	1490	400/690	1150	15'305.00

6Pol 900 min.-1 - 6 pôles 900 t/min.

Artikel N° (B3)	Typ H				P _N kW	T _N (Nm)	I _N A 400V	η _N %			cos.	n _N min.-1	Volt	kg	CHF
								50%	75%	100%					
SE23049	4SIE	200	LA	6	18.5	178	35.5	92.1	93.3	93.4	0.81	990	400/690	297	5'096.00
SE23082	4SIE	200	LB	6	22	212	42	92.3	93.5	93.7	0.80	990	400/690	320	5'380.00
SE23115	4SIE	225	M	6	30	289	56	93.2	94.2	94.2	0.82	991	400/690	405	6'618.00
SE23148	4SIE	250	M	6	37	356	71	93.4	94.4	94.5	0.80	992	400/690	452	7'957.00
SE23181	4SIE	280	S	6	45	434	81	94.6	95.2	94.8	0.85	991	400/690	649	9'914.00
SE23214	4SIE	280	M	6	55	530	99	94.8	95.4	95.1	0.84	991	400/690	712	10'839.00
SE23247	4SIE	315	S	6	75	723	137	94.6	95.3	95.4	0.83	991	400/690	922	15'087.00
SE23280	4SIE	315	MA	6	90	867	160	94.8	95.5	95.6	0.85	991	400/690	987	17'295.00
SE23313	4SIE	315	MB	6	110	1059	195	95.1	95.8	95.8	0.85	992	400/690	1135	18'834.00

• Zuschläge auf Basisausführung B3 / • Supplément de prix pour la forme B3
IEC 200-315 B5; +5%; IEC 200-315 - B3B5; +7%;

**3Ph Lüfter-Motoren
mit quadratischem Moment**

- 2 getrennte Wicklungen
- 3Ph Motoren nach IEC 60034-30
- Weitbereichsspannung 400 Volt +/- 10 %, 50/60 Hz
- Schutzart IP55 • Isolationsklasse „F“ • Betriebsart S1
- Leistungsbereich von 0.06kW bis 37kW
- Nenn Drehzahl 900/1400min.-1; 6/4Pol Motoren
- Typ: ShzW = Variable Klemmenkastenposition "Multifuss"

**Moteurs à pôles commutables pour la ventilation
couple quadratique**

- Bobinages séparés
- Moteurs conformes à la directive IEC 60034-30
- Large plage de tension 400 Volt +/- 10 %, 50/60 Hz
- Protection IP55 • Classe d'isolation F • Service continu S1
- Puissance de 0.06 à 37kW
- Vitesse nominale 900/1400 t/min. ; 6/4pôles
- Typ: ShzW/= Position boîte à bornes variable "multiplié"

vsh

Artikel N° (B3)	Typ				P _N kW	T _N (Nm)	I _N A 400V	η _N %	n _N min.-1	Volt	kg	CHF
	ShW	H										
31120	ShW	71	A	<u>6</u> 4	<u>0.06</u> 0.18	<u>0.61</u> 1.23	<u>0.5</u> 1.1	<u>35.0</u> 45.0	<u>940</u> 1400	400	4.9	221.30
31150	ShW	71	B	<u>6</u> 4	<u>0.18</u> 0.25	<u>1.95</u> 1.77	<u>0.8</u> 1.0	<u>50.0</u> 50.0	<u>880</u> 1350	400	6.0	241.30
31180	ShzW	80	A	<u>6</u> 4	<u>0.12</u> 0.37	<u>1.19</u> 2.54	<u>0.8</u> 1.2	<u>42.0</u> 59.0	<u>960</u> 1390	400	7.5	265.05
31210	ShzW	80	B	<u>6</u> 4	<u>0.18</u> 0.55	<u>1.77</u> 3.81	<u>0.9</u> 1.4	<u>50.0</u> 68.0	<u>970</u> 1380	400	8.6	293.65
31240	ShzW	90	S	<u>6</u> 4	<u>0.28</u> 0.8	<u>2.81</u> 5.42	<u>0.9</u> 2.1	<u>62.9</u> 66.9	<u>950</u> 1410	400	13.8	433.60
31270	ShzW	90	L	<u>6</u> 4	<u>0.37</u> 1.1	<u>3.74</u> 7.45	<u>1.1</u> 2.9	<u>59.2</u> 67.7	<u>945</u> 1410	400	16.7	499.25
31299	ShzW	100	LA	<u>6</u> 4	<u>0.6</u> 1.7	<u>6.03</u> 11.5	<u>2.0</u> 4.2	<u>58.1</u> 71.6	<u>950</u> 1410	400	23.8	573.60
31300	ShzW	100	LB	<u>6</u> 4	<u>0.75</u> 2.2	<u>7.46</u> 14.9	<u>2.2</u> 5.2	<u>64.9</u> 73.0	<u>960</u> 1415	400	25.5	673.00
31330	ShzW	112	M	<u>6</u> 4	<u>0.9</u> 3.0	<u>8.82</u> 20.2	<u>2.6</u> 6.6	<u>73</u> 78.4	<u>975</u> 1420	400	33.3	784.75
31360	ShW	132	S	<u>6</u> 4	<u>1.2</u> 3.4	<u>12.2</u> 22.4	<u>2.9</u> 7.0	<u>69.3</u> 80.0	<u>940</u> 1450	400	56.0	1'024.95
31390	ShW	132	M	<u>6</u> 4	<u>1.7</u> 4.5	<u>17.1</u> 29.6	<u>3.8</u> 8.9	<u>75.5</u> 82.7	<u>950</u> 1450	400	67.0	1'487.25
31390.z	SIEzW	132	M	<u>6</u> 4	<u>1.7</u> 4.5	<u>17.1</u> 29.6	<u>3.8</u> 8.9	<u>75.5</u> 82.7	<u>950</u> 1450	400	67.0	1'986.70
31420	ShW	160	M	<u>6</u> 4	<u>2.5</u> 6.7	<u>25.7</u> 44.1	<u>5.6</u> 13.7	<u>75.1</u> 82.2	<u>930</u> 1450	400	95.0	2'147.10
31450	ShW	160	L	<u>6</u> 4	<u>3.3</u> 10	<u>33.2</u> 65.6	<u>6.9</u> 19.9	<u>79.2</u> 85.0	<u>950</u> 1455	400	125	2'814.65
31510	ShW	180	L	<u>6</u> 4	<u>6.2</u> 13	<u>61.0</u> 84.5	<u>12.4</u> 24.7	<u>82.0</u> 85.4	<u>970</u> 1470	400	165	5'204.75
31540	ShW	200	L	<u>6</u> 4	<u>9.0</u> 26	<u>87.0</u> 169	<u>17.0</u> 46.0	<u>84.0</u> 88.5	<u>980</u> 1470	400	260	6'448.00
31577	ShW	225	S	<u>6</u> 4	<u>12</u> 33	<u>116</u> 214	<u>22.0</u> 56.0	<u>87.5</u> 91.4	<u>988</u> 1473	400	330	8'126.00
31570	ShW	225	M	<u>6</u> 4	<u>13</u> 37	<u>126</u> 239	<u>25.0</u> 65.0	<u>88.1</u> 91.7	<u>989</u> 1479	400	365	9'714.90

- Zuschläge auf Basisausführung B3 / • Supplément de prix pour la forme B3
- IEC 71-112** - B5; B14-1; B14-2 **+7%**; **IEC 71-112** - B3B5; B3B14-1; B3B14-2 **+9%**;
- IEC 132-225** B5; B14-1; B14-2 **+5%**; **IEC 132-225** - B3B5; B3B14-1; B3B14-2 **+7%**;

**3Ph Polumschaltbare-Motoren
mit konstantem Moment**

- 2 getrennte Wicklungen
- 3Ph Motoren nach IEC 60034-30
- Weitbereichsspannung 400 Volt +/- 10 %, 50/60 Hz
- Schutzart IP55 • Isolationsklasse „F“ • Betriebsart S1
- Leistungsbereich von 0.25kW bis 13kW
- Nenndrehzahl 900/1400min.-1; 6/4Pol Motoren
- Typ: ShzW = Variable Klemmenkastenposition "Multifuss"

**Moteurs à pôles commutables
couple constant**

- Bobinages séparés
- Moteurs conformes à la directive IEC 60034-30
- Large plage de tension 400 Volt +/- 10 %, 50/60 Hz
- Protection IP55 • Classe d'isolation F • Service continu S1
- Puissance de 0.25 à 13kW
- Vitesse nominale 900/1400 t/min. ; 6/4pôles
- Typ: Shz/= Position boîte à bornes variable "multiplied"

SSS

Artikel N° (B3)	Typ H				P _N kW	T _N (Nm)	I _N A 400V	η _N %	n _N min.-1	Volt	kg	CHF
	Shz											
41210	Shz	80	C	6 4	0.25 0.75	2.51 5.08	1.0 2.0	52.0 66.0	950 1410	400	11.0	345.10
41240	Shz	90	S	6 4	0.63 0.90	6.33 6.03	2.2 2.5	63.7 66.5	950 1425	400	15.4	431.30
41270	Shz	90	L	6 4	0.70 1.10	7.15 7.45	2.2 2.9	63.0 67.7	935 1410	400	16.7	489.05
41280	Shz	100	LA	6 4	0.9 1.3	8.95 8.62	2.9 3.5	65.5 68.2	960 1440	400	21.5	569.75
41300	Shz	100	LB	6 4	1.2 1.7	11.9 11.3	3.2 4.1	73.0 74.0	960 1435	400	26.0	667.95
41330	Shz	112	M	6 4	1.6 2.4	15.7 15.8	4.1 5.4	74.8 81.1	975 1455	400	35.5	779.35
41360	Sh	132	S	6 4	2.5 3.5	24.6 23.2	6.4 7.0	77.0 81.0	970 1440	400	60.0	1'011.60
41390	Sh	132	M	6 4	3.1 4.7	30.7 31.1	7.4 9.4	79.3 81.7	965 1445	400	70.0	1'468.25
41420	Sh	160	M	6 4	5.2 7.4	51.5 48.7	11.0 14.3	83.2 84.9	965 1450	400	110	2'116.70
41450	Sh	160	L	6 4	7.0 10.8	68.9 71.2	15.0 20.4	85.0 86.8	970 1450	400	135	2'777.40
41510	Sh	180	L	6 4	8.5 13	82.4 84.5	18.2 24.7	84.2 85.4	985 1470	400	165	3'797.35

- Zuschläge auf Basisausführung B3 / • Supplément de prix pour la forme B3
- IEC 80-112** - B5; B14-1; B14-2 +7%; **IEC 80-112** - B3B5; B3B14-1; B3B14-2 +9%;
- IEC 132-180** B5; B14-1; B14-2 +5%; **IEC 132-180** - B3B5; B3B14-1; B3B14-2 +7%;



3Ph Polumschaltbare-Motoren

- Dahlander Wicklung
- 3Ph Motoren nach IEC 60034-30
- Weitbereichsspannung 400 Volt +/- 10 %, 50/60 Hz
- Schutzart IP55 • Isolationsklasse „F“ • Betriebsart S1
- Leistungsbereich von 0.21kW bis 24kW
- Nenndrehzahl 1400/2800min.-1; 4/2Pol Motoren
- Typ: Shz = Variable Klemmenkastenposition "Multifuss"

Moteurs à pôles commutables triphasés

- Bobinage Dahlander
- Moteurs conformes à la directive IEC 60034-30
- Large plage de tension 400 Volt +/- 10 %, 50/60 Hz
- Protection IP55 • Classe d'isolation F • Service continu S1
- Puissance de 0.21kW à 24kW
- Vitesse nominale 1400/2800 t/min. ; 4/2pôles
- Typ: Shz/= Position boîte à bornes variable "multiplied"

DSH

Artikel N° (B3)	Typ				P _N kW	T _N (Nm)	I _N A 400V	η _N %	n _N min.-1	Volt	kg	CHF
	Sh	H										
58120	Sh	71	A	$\frac{4}{2}$	<u>0.21</u> 0.28	<u>1.43</u> 0.96	<u>0.95</u> 1.25	<u>58.0</u> 50.0	<u>1400</u> 2800	400	4.9	233.50
58220	Sh	71	B	$\frac{4}{2}$	<u>0.30</u> 0.45	<u>2.05</u> 1.52	<u>1.20</u> 1.62	<u>68.0</u> 60.0	<u>1400</u> 2820	400	5.8	239.20
58320	Sh	71	C	$\frac{4}{2}$	<u>0.50</u> 0.70	<u>3.51</u> 2.4	<u>1.6</u> 2.2	<u>68.0</u> 64.0	<u>1360</u> 2790	400	7.8	277.45
58420	Shz	80	A	$\frac{4}{2}$	<u>0.45</u> 0.60	<u>3.16</u> 2.09	<u>1.5</u> 1.9	<u>59.0</u> 60.0	<u>1360</u> 2740	400	7.8	275.10
58520	Shz	80	B	$\frac{4}{2}$	<u>0.75</u> 0.95	<u>5.23</u> 3.26	<u>2.1</u> 2.5	<u>69.0</u> 70.0	<u>1360</u> 2780	400	10.2	325.20
58620	Shz	90	S	$\frac{4}{2}$	<u>1.1</u> 1.4	<u>7.45</u> 4.80	<u>2.8</u> 3.1	<u>72.0</u> 73.1	<u>1410</u> 2785	400	14.0	398.75
58720	Shz	90	L	$\frac{4}{2}$	<u>1.4</u> 2.0	<u>9.52</u> 6.94	<u>3.4</u> 4.3	<u>73.7</u> 74.3	<u>1405</u> 2750	400	16.2	437.60
58820	PShz	90	LP	$\frac{4}{2}$	<u>1.6</u> 2.4	<u>10.9</u> 8.24	<u>3.7</u> 4.5	<u>73.7</u> 82.6	<u>1405</u> 2780	400	21.5	481.70
58920	Shz	100	LA	$\frac{4}{2}$	<u>2.0</u> 2.6	<u>13.7</u> 8.80	<u>4.2</u> 5.3	<u>77.5</u> 76.9	<u>1395</u> 2810	400	25.0	568.55
59020	Shz	100	LB	$\frac{4}{2}$	<u>2.5</u> 3.3	<u>17.3</u> 11.3	<u>5.2</u> 6.7	<u>77.9</u> 78.0	<u>1380</u> 2785	400	27.0	668.05
59120	Shz	112	M	$\frac{4}{2}$	<u>3.3</u> 4.5	<u>22.0</u> 15.0	<u>6.7</u> 9.0	<u>83.3</u> 81.7	<u>1435</u> 2865	400	33.0	850.85
59220	Sh	132	S	$\frac{4}{2}$	<u>4.7</u> 5.7	<u>31.1</u> 18.8	<u>9.3</u> 11.5	<u>84.0</u> 78.0	<u>1445</u> 2895	400	61.0	1'116.90
59320	Sh	132	M	$\frac{4}{2}$	<u>6.0</u> 7.2	<u>39.5</u> 23.6	<u>11.8</u> 14.0	<u>85.0</u> 80.5	<u>1450</u> 2915	400	70.0	1'339.00
59420	Sh	132	MB	$\frac{4}{2}$	<u>6.2</u> 7.5	<u>40.8</u> 24.5	<u>12.4</u> 14.8	<u>83.9</u> 81.0	<u>1450</u> 2920	400	72.0	1'362.70
59520	PSh	132	MP	$\frac{4}{2}$	<u>7.5</u> 10	<u>49.2</u> 32.7	<u>14.8</u> 18.8	<u>85.4</u> 83.2	<u>1455</u> 2920	400	81.0	1'863.10
59620	Sh	160	M	$\frac{4}{2}$	<u>10</u> 12	<u>65.9</u> 39.5	<u>19.7</u> 22.1	<u>87.3</u> 85.0	<u>1450</u> 2900	400	110	1'990.95
59720	Sh	160	L	$\frac{4}{2}$	<u>13</u> 16	<u>85.3</u> 52.4	<u>25.1</u> 29.1	<u>88.0</u> 86.4	<u>1455</u> 2915	400	130	2'550.95
59820	Sh	180	M	$\frac{4}{2}$	<u>14.5</u> 19.5	<u>94.2</u> 63.6	<u>30.1</u> 35.8	<u>88.0</u> 85.5	<u>1470</u> 2930	400	155	3'131.70
59920	Sh	180	L	$\frac{4}{2}$	<u>17.5</u> 24	<u>113</u> 77.9	<u>37.0</u> 43.7	<u>88.5</u> 87.0	<u>1480</u> 2940	400	175	3'693.10

- Zuschläge auf Basisausführung B3 / • Supplément de prix pour la forme B3
- IEC 71-112** - B5; B14-1; B14-2 **+7%**; **IEC 71-112** - B3B5; B3B14-1; B3B14-2 **+9%**;
- IEC 132-180** B5; B14-1; B14-2 **+5%**; **IEC 132-180** - B3B5; B3B14-1; B3B14-2 **+7%**;

3Ph Polumschaltbare-Motoren

- Dahlander Wicklung
- 3Ph Motoren nach IEC 60034-30
- Weitbereichsspannung 400 Volt +/- 10 %, 50/60 Hz
- Schutzart IP55 • Isolationsklasse „F“ • Betriebsart S1
- Leistungsbereich von 0.22kW bis 27kW
- Nenndrehzahl 700/1400min.-1; 8/4Pol Motoren
- Typ: Shz = Variable Klemmenkastenposition "Multifuss"

Moteurs à pôles commutables triphasés

- Bobinage Dahlander
- Moteurs conformes à la directive IEC 60034-30
- Large plage de tension 400 Volt +/- 10 %, 50/60 Hz
- Protection IP55 • Classe d'isolation F • Service continu S1
- Puissance de 0.22kW à 27kW
- Vitesse nominale 700/1400 t/min. ; 8/4pôles
- Typ: Shz/= Position boîte à bornes variable "multiplied"

DSH

Artikel N° (B3)	Typ H				P _N kW	T _N (Nm)	I _N A 400V	η _N %	n _N min.-1	Volt	kg	CHF
	Shz											
68420	Shz	80	A	8/4	0.22 0.40	3.14 2.83	1.3 1.1	46.0 60.0	670 1350	400	7.3	277.55
68520	Shz	80	B	8/4	0.30 0.55	4.34 3.89	1.5 1.4	48.0 64.0	660 1350	400	8.6	297.40
68620	Shz	90	S	8/4	0.37 0.75	5.01 5.17	1.7 1.7	55.2 72.9	705 1385	400	14.9	464.55
68720	Shz	90	L	8/4	0.55 1.00	7.56 6.92	2.1 2.2	62.1 74.7	695 1380	400	16.6	542.40
68920	Shz	100	LA	8/4	0.70 1.25	9.35 8.38	2.8 2.8	64.2 77.7	715 1425	400	23.8	580.10
69020	Shz	100	LB	8/4	0.90 1.70	12.0 11.5	3.2 3.7	67.0 76.5	715 1415	400	26.0	746.05
69120	Shz	112	M	8/4	1.60 3.00	21.4 20.2	5.1 6.3	74.4 80.3	715 1415	400	33.0	880.15
69220	Sh	132	S	8/4	2.50 4.20	33.6 28.4	6.9 8.2	77.5 81.6	710 1410	400	62.0	1'193.20
69320	Sh	132	M	8/4	3.20 5.40	43.0 36.4	8.7 10.4	78.6 82.4	710 1415	400	73.0	1'414.90
69620	Sh	160	M	8/4	4.70 8.40	61.9 55.9	13.0 15.5	82.7 86.1	725 1435	400	105	2'324.25
69720	Sh	160	L	8/4	7.20 12.0	95.5 79.6	19.4 22.0	83.9 87.3	720 1440	400	130	2'830.85
69920	Sh	180	L	8/4	10.0 15.8	131 103	24.2 29.5	85.0 86.0	730 1460	400	165	3'994.65
69930	Sh	200	L	8/4	17.0 27.0	219 175	40 48.5	85.2 87.6	740 1470	400	255	5'502.15

- Zuschläge auf Basisausführung B3 / • Supplément de prix pour la forme B3
- IEC 80 -112** - B5; B14-1; B14-2 +7%; **IEC 80 -112** - B3B5; B3B14-1; B3B14-2 +9%;
- IEC 132-200** B5; B14-1; B14-2 +5%; **IEC 132-200** - B3B5; B3B14-1; B3B14-2 +7%;



SEMh
1 Ph Motoren mit Betriebskondensator

- 1Ph Motoren nach IEC 60031-30
- Schutzart IP 55
- Isolationsklasse „F“ • Betriebsart S1
- Leistungsbereich von 0.09kW bis 1.5kW
- Typ: SEMhz = Variable Klemmenkastenposition "Multifuss"

Moteurs monophasés avec condensateur

- Moteurs conformes à la directive IEC 60031-30
- Protection IP 55
- Classe d'isolation F • Service continu S1
- Puissance de 0.09kW à 1.5kW
- Typ: SEMhz/= Position boîte à bornes variable "multiplié"

Artikel N° (B3)	Typ H				P _N kW	T _N (Nm)	I _N A 400V	η _N %	n _N min.-1	Volt	C _B (μF)		kg	CHF
122510	SEMh	56	B	2	0.09	0.31	0.85	53	2790	230	5	–	3.5	156.65
122540	SEMh	56	C	2	0.12	0.41	1.20	54	2800	230	5	–	3.8	157.30
122600	SEMh	63	B	2	0.18	0.62	1.80	52	2760	230	8	–	4.4	182.05
122630	SEMh	63	C	2	0.25	0.85	2.00	63	2800	230	10	–	5.2	191.50
122690	SEMh	71	B	2	0.37	1.26	3.00	64	2800	230	12	–	6.4	206.65
122720	SEMh	71	C	2	0.55	1.88	3.60	70	2780	230	20	–	7.7	234.15
122780.z	SEMhz	80	B	2	0.75	2.56	5.00	70	2800	230	25	–	9.7	307.20
122810.z	SEMhz	80	C	2	1.1	3.75	6.40	76	2780	230	30	–	11.7	337.80
122840.z	SEMhz	80	D	2	1.5	5.31	10.2	71	2700	230	40	–	13.5	410.70
122870	SEMh	90	S	2	1.1	3.81	6.4	76	2780	230	30	–	11.7	338.00
122900	SEMh	90	L	2	1.5	5.31	10.2	71	2700	230	40	–	15.2	381.50

• Zuschläge auf Basisausführung B3 / • Supplément de prix pour la forme B3
IEC 56-90- B5; B14-1; B14-2 +7%; IEC 56-90 - B3B5; B3B14-1; B3B14-2 +9%;

1 Ph Motoren mit Betriebskondensator und verstärktem Anlauf

- 1Ph Motoren nach IEC 60031-30
- Schutzart IP 55
- Isolationsklasse „F“
- Betriebsart S1
- Leistungsbereich von 0.37kW bis 2.5kW

Moteurs monophasés avec condensateur et démarrage renforcé

- Moteurs conformes à la directive IEC 60031-30
- Protection IP 55
- Classe d'isolation F
- Service continu S1
- Puissance de 0.37kW à 2.5kW

EMD

Artikel N° (B3)	Typ H				P _N kW	T _N (Nm)	I _N A 400V	η _N %	n _N min.-1	Volt	C _B (μF)		kg	CHF
125720	EMD	71	A	2	0.37	1.31	3.20	61	2700	230	12	63-80	7.0	368.55
125730	EMD	71	B	2	0.55	1.92	4.30	61	2730	230	16	63-80	8.3	388.50
125740	EMD	80	A	2	0.75	2.58	5.10	68	2770	230	20	63-80	10.0	429.25
125750	EMD	80	B	2	1.1	3.82	7.10	70	2750	230	25	80-100	11.8	440.60
125760	EMD	80	C	2	1.5	5.3	9.80	70	2700	230	35	80-100	12.5	462.00
125770	EMD	90	SB	2	1.5	5.2	9.20	75	2750	230	40	100-125	15.0	559.85
125780	EMD	90	LA	2	1.85	6.35	10.7	76	2780	230	50	100-125	16.8	592.60
125790	EMD	90	LB	2	2.2	6.67	12.7	76	2740	230	60	100-125	16.8	600.40
125800	EMD	100	LA	2	2.5	8.40	14.7	73	2850	230	80	125-156	22.4	680.80

• Zuschläge auf Basisausführung B3 / • Supplément de prix pour la forme B3
IEC 71 - 100- B5; B14-1; B14-2 +7%; IEC 71 - 100 - B3B5; B3B14-1; B3B14-2 +9%;

1 Ph Motoren mit Betriebskondensator

- 1Ph Motoren nach IEC 60031-30
- Schutzart IP 55
- Isolationsklasse „F“ • Betriebsart S1
- Leistungsbereich von 0.06kW bis 1.1kW
- Typ: SEMhz = Variable Klemmenkastenposition "Multifuss"

Moteurs monophasés avec condensateur

- Moteurs conformes à la directive IEC 60031-30
- Protection IP 55
- Classe d'isolation F • Service continu S1
- Puissance de 0.06kW à 1.1kW
- Typ: SEMhz/= Position boîte à bornes variable "multiplié"

SEMh

Artikel N° (B3)	Typ H				P _N kW	T _N (Nm)	I _N A 400V	η _N %	n _N min.-1	Volt	C _B (μF)		kg	CHF
123920	SEMh	56	B	4	0.06	0.41	0.85	39	1390	230	4	–	3.3	161.70
123950	SEMh	56	C	4	0.09	0.63	1.10	50	1360	230	5	–	3.6	165.90
124010	SEMh	63	B	4	0.12	0.84	1.25	53	1360	230	6	–	4.3	180.80
124040	SEMh	63	C	4	0.18	1.27	1.72	58	1350	230	8	–	5.1	191.50
124070	SEMh	71	B	4	0.25	1.78	2.50	56	1340	230	10	–	6.3	207.90
124100	SEMh	71	C	4	0.37	2.68	3.20	59	1320	230	16	–	7.4	223.85
124160.z	SEMhz	80	B	4	0.55	3.86	3.90	68	1360	230	20	–	9.6	313.40
124190.z	SEMhz	80	C	4	0.75	5.35	5.60	65	1340	230	25	–	11.5	352.85
124220	SEMh	90	S	4	0.75	5.19	5.60	65	1340	230	25	–	12.5	358.00
124250	SEMh	90	L	4	1.1	8.08	7.80	67	1300	230	40	–	14.5	391.20

- Zuschläge auf Basisausführung B3 / • Supplément de prix pour la forme B3
- IEC 56-90- B5; B14-1; B14-2 +7%; IEC 56-90 - B3B5; B3B14-1; B3B14-2 +9%;**

1 Ph Motoren mit Betriebskondensator und verstärktem Anlauf

- 1Ph Motoren nach IEC 60031-30
- Schutzart IP 55
- Isolationsklasse „F“
- Betriebsart S1
- Leistungsbereich von 0.25kW bis 2.2kW

Moteurs monophasés avec condensateur et démarrage renforcé

- Moteurs conformes à la directive IEC 60031-30
- Protection IP 55
- Classe d'isolation F
- Service continu S1
- Puissance de 0.25kW à 2.2kW

EMD

Artikel N° (B3)	Typ H				P _N kW	T _N (Nm)	I _N A 400V	η _N %	n _N min.-1	Volt	C _B (μF)		kg	CHF
125830	EMD	71	A	4	0.25	1.80	2.00	60	1330	230	10	20	6.5	365.40
125840	EMD	71	B	4	0.37	2.72	3.20	55	1300	230	14	63-80	8.0	380.10
125850	EMD	80	A	4	0.55	3.86	3.70	64	1360	230	16	63-80	9.0	423.15
125860	EMD	80	B	4	0.75	5.10	5.30	65	1400	230	20	63-80	10.5	441.20
125870	EMD	90	S	4	1.1	7.72	7.00	72	1360	230	35	60-100	13.4	543.25
125880	EMD	90	LA	4	1.5	10.8	9.30	73	1360	230	45	100-125	16.2	584.00
125890	EMD	90	LB	4	1.85	13.0	12.1	73	1360	230	55	100-125	18.2	634.20
125900	EMD	100	LA	4	1.85	13.0	12.2	70	1360	230	55	100-125	21.6	674.75
125910	EMD	100	LB	4	2.2	15.6	13.0	76	1350	230	70	125-156	24.0	745.50

- Zuschläge auf Basisausführung B3 / • Supplément de prix pour la forme B3
- IEC 71 - 100- B5; B14-1; B14-2 +7%; IEC 71 - 100 - B3B5; B3B14-1; B3B14-2 +9%;**

- Fremdlüfteraggregate für Asynchron- und Gleichstrommotoren ab Baugröße 63
- Geringe Variantenvielfalt durch Multivoltkonzeption 230V 1~ bis 575V 3~
- Ventilations forcées pour moteurs asynchrones et moteurs à courant continu à partir de la taille 63
- Conception multi-tension 230V 1~ à 575V 3~

FLAI

Artikel N°	Typ	ø D mm	L mm	Motor L * mm	[m³/h]	Volt	CHF	Montage	
								A. N°	CHF
1500001	63 Sh	121	180	290 (+E)	54	1~ 230 Δ oder 3~ 230 / 400-500	302.95	210100	36.-
1500002	71 Sh	133	185	325 (+E)	78		322.35		
1500003	80 Sh/2SIE/3SIE	149	200	360 (+E)	127		349.15		
1500004	90 Sh/2SIE	174	205	445 (+E)	200		390.80		
PE1500004	90 3SIE	192	220	401 (+E)	200		410.35		
1500005	100 Sh/2SIE	192	205	460 (+E)	260		405.30		
PE1500005	100 3SIE	208	240	473 (+E)	260		425.55		
1500006	112 Sh/2SIE	232	235	480 (+E)	337		405.30		
PE1500006	112 3SIE	238	242	482 (+E)	337		425.55		
1550021	132 Sh/2SIE	265	275	575 (+E)	532		518.70		
PE1550019	132 3SIE/4SIE	278	275	622 (+E)	532		560.20		
1550022	160 Sh/2SIE	312	330	690 (+E)	935		627.90		
PE1550020	160 3SIE/4SIE	333	330	738 (+E)	935		672.75		
1500007	180 Sh/2SIE/3SIE	345	340	770 (+E)	1145		791.70		
1500008	200 2SIE/3SIE/4SIE	430	415	955 (+E)	1263		856.80		
1500009	225 2SIE/3SIE/4SIE	480	469	980 (+E)	1123		1'202.25		
1500010	250 2SIE/3SIE/4SIE	515	518	1050 (+E)	1666		1'588.65		
1500011	280 2SIE/3SIE/4SIE	594	567	1150 (+E)	2116		1'813.35		
1500012	315 2SIE/3SIE/4SIE	594	567	1240 (+E)	2662	2'044.35			

* Richtwerte, genaue Masse auf Anfrage * Valeur indicative, mesure exacte sur demande.

- Bei Anwendung im Freien mit Montage in Position V5 - V18 - V1 - V15 empfiehlt sich die Montage eines Regenschutzdaches.
- Grundiert (ohne Lackierung) zum Schrauben, Nieten oder Schweißen auf Originalhaube.
- Pour des applications en plein air avec montage en position V5 – V18 – V1 – V15, il est recommandé de monter un capot de protection contre la pluie.
- non peint (vernis de fond) à visser ou souder sur le capot de ventilation d'origine.

REG

Artikel N°	Typ	ø D mm	H mm	CHF	Montage		
					A. N°	CHF	
1500100	56 Sh	ø 107	17	34.55	210110	28.00	
1500101	63 Sh	ø 118	18	34.55			
1500102	71 Sh	ø 133	19	35.85			
1500103	80 Sh/2SIE/3SIE/4SIE	ø 150	19	38.55			
1500104	90 Sh/2SIE	ø 170	24	42.55			
1500105	100 Sh/2SIE	ø 180	25	45.15			
1500106	112 Sh/2SIE	90-100 3SIE/4SIE	ø 210	31			54.40
1500107	132 Sh/2SIE	112 3SIE/4SIE	ø 249	33			67.75
1500107.1	132 3SIE/4SIE	ø 278	33	71.95			
1500108	160 Sh/2SIE	ø 300	41	78.40			210111
1500109	180 Sh/2SIE	160-180 3SIE/4SIE	ø 338	46	94.30	210112	68.00
1500110	200 2SIE/3SIE/4SIE	ø 372	57	130.20			
1500111	225 2SIE/3SIE/4SIE	ø 424	60	159.40			
1500112	250 2SIE/3SIE/4SIE	ø 460	62	212.50			
1500113	280 2SIE/3SIE/4SIE	ø 510	69	239.10	210113	98.00	
1500114	315 2SIE/3SIE/4SIE	ø 570	75	301.35			

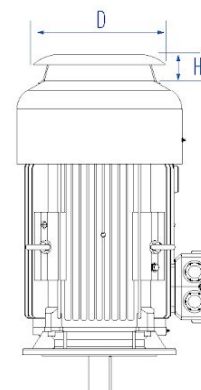
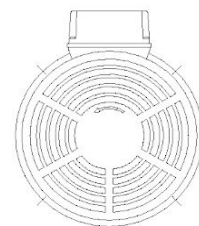
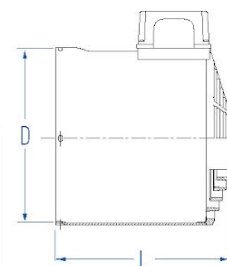

- Original Ersatzteile zu Cantoni Elektromotoren der Baugröße IEC 56 - 80
- Pièces de rechange pour moteurs Cantoni grandeur IEC 56 -80

Bezeichnung		Description		56	63	71	80			
1	Lagerschild AS (DE)	palier roulement AS (côté A)	A.N°	140000	140010	140018	140026			
			Preis	26.25	29.40	31.50	33.60			
2	Flansch B14-1	flasque B14-1	A.N°	140001	140011	140019	140027			
			Preis	51.45	53.55	63.00	68.25			
3	Flansch B14-2 (Typ F = 8 Loch)	flasque B14-2 (type F = 8 trous)	A.N°	140002	140012	140012.F	140020	140020.F	140028	140028.F
			Preis	44.10	48.30	57.90	57.75	69.30	56.70	68.05
4	Flansch B5 (Typ F = 8 Loch)	flasque B5 (type F = 8 trous)	A.N°	140003	140013	140021	140029	140029.F		
			Preis	51.45	57.75	68.25	81.90	94.20		
5	Klemmenbrett	bornier	A.N°	140004						
			Preis	12.60						
6	Klemmenkasten	boîte à bornes	A.N°	140005			140030			
			Preis	58.80			60.90			
7	Lagerschild GS (NDE)	palier roulement GS (côté B)	A.N°	140006	140014	140022	140031			
			Preis	26.25	29.40	31.50	33.60			
8	Ventilatorflügel	ventilateur	A.N°	140007	140015	140023	140032			
			Preis	8.40	8.40	10.50	11.55			
9	Haube	capot	A.N°	140008	140016	140024	140033			
			Preis	24.15	27.30	29.40	33.60			
10	Füsse	pied	A.N°	140009	140017	140025	140034			
			Preis	22.05	22.05	33.60	44.10			

CSP

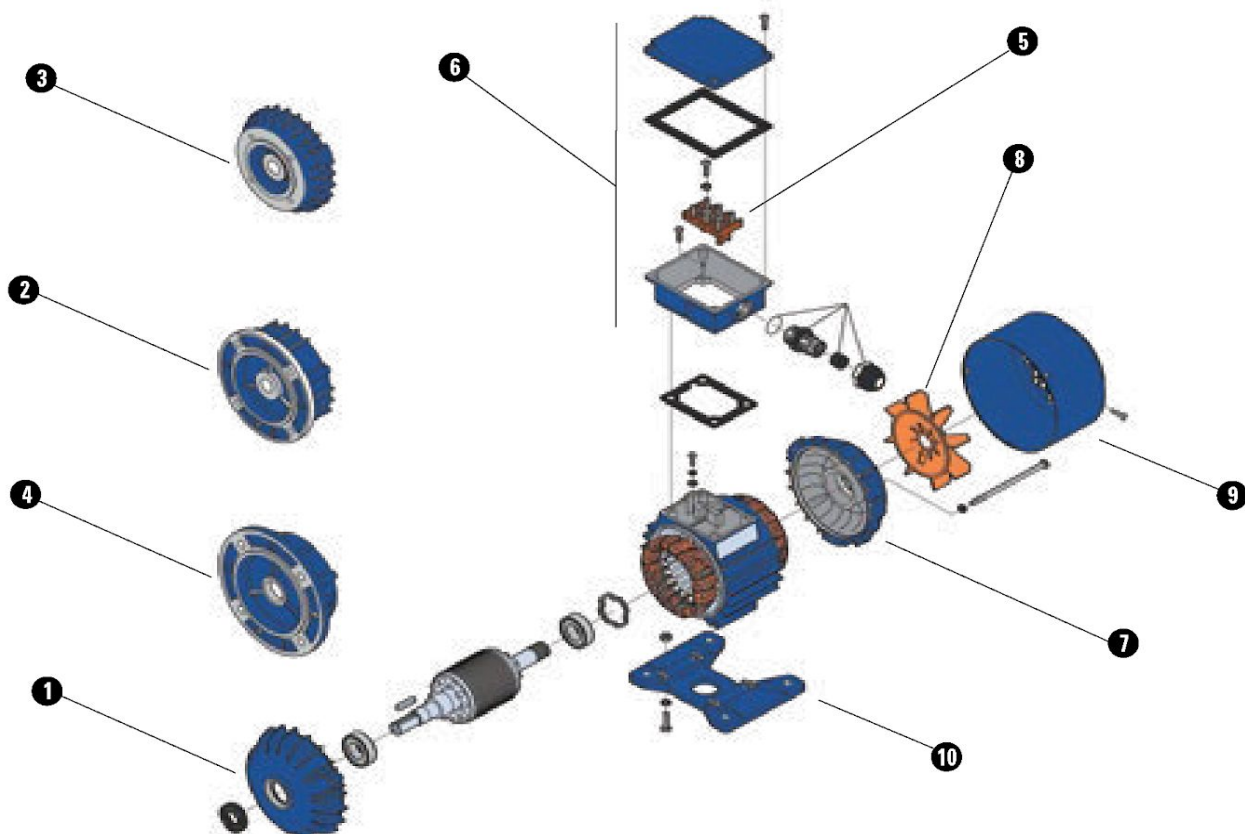

- Original Ersatzteile zu Cantoni Elektromotoren der Baugrösse IEC 90 - 180
- Pièces de rechange pour moteurs Cantoni grandeur IEC 90 - 180

Bezeichnung		Description		90	100	112	132	160	180
1	Lagerschild AS (DE)	palier roulement AS (côté A)	A.N°	PE140100	PE140110	PE140118	PE140126	PE140137	PE140146
			Preis	55.65	88.20	88.20	112.35	163.80	252.00
2	Flansch B14-1	flasque B14-1	A.N°	PE140101	PE140111	PE140119	PE140127	PE140138	
			Preis	98.70	148.05	159.60	190.05	313.60	
3	Flansch B14-2	flasque B14-2	A.N°	PE140102	PE140112	PE140120	PE140128		
			Preis	98.70	148.05	159.60	190.05		
4	Flansch B5	flasque B5	A.N°	PE140103	PE140113	PE140121	PE140129	PE140139	PE140147
			Preis	81.90	131.25	145.95	160.65	306.60	364.35
5	Klemmenbrett	bornier	A.N°	140104				140140	
			Preis	22.05				51.45	
6	Klemmenkasten	boîte à bornes	A.N°	140105			140130	140141	
			Preis	96.60			162.75	162.75	
7	Lagerschild GS (NDE)	palier roulement GS (côté B)	A.N°	PE140106	PE140114	PE140122	PE140131	PE140142	PE140148
			Preis	55.65	88.20	88.20	112.35	163.80	252.00
8	Ventilatorflügel	ventilateur	A.N°	PE140107	PE140115	PE140123	140132	140143	140149
			Preis	15.75	28.35	28.35	63.00	69.30	82.95
9	Haube	capot	A.N°	PE140108	PE140116	PE140124	PE140134	PE140145	PE140151
			Preis	29.40	29.40	33.60	47.25	59.85	96.60
10	Füsse	pied	A.N°	PE140109	PE140117	PE140125	PE140135	PE140136	PE140152
			Preis	30.45	30.45	31.50	65.10	92.40	102.90

- Bei IE1, IE2, IE3 & IE4 Motoren ist die Kompatibilität nicht bei allen Typen gewährleistet.
- Pour les moteurs IE1, IE2, IE3 et IE4 la compatibilité n'est pas assurée pour tous les types.

CSP

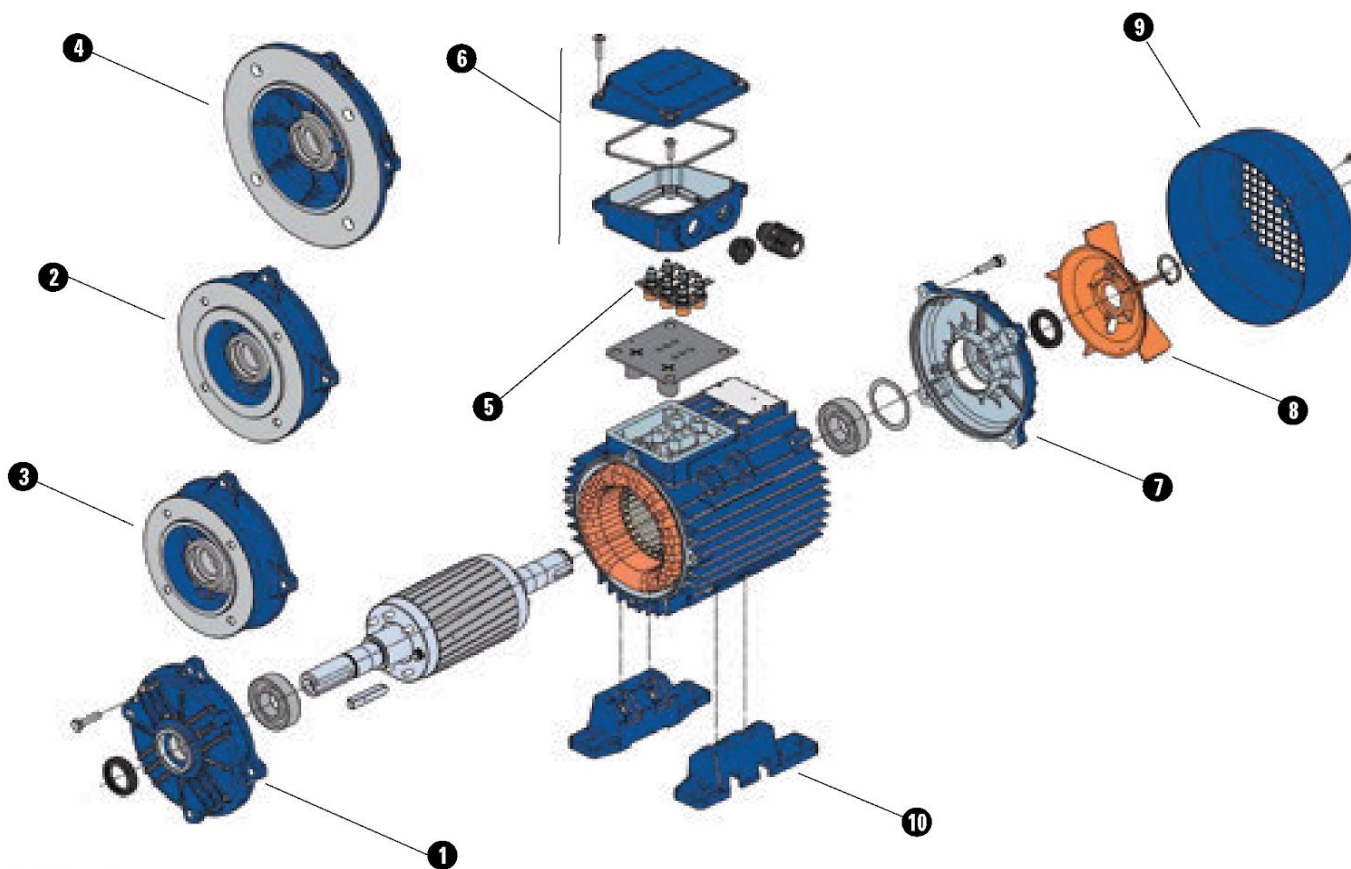

- Original Ersatzteile zu Cantoni Elektromotoren der Baugrösse IEC 200 - 315
- Pièces de rechange pour moteurs Cantoni grandeur IEC 200 - 315

Bezeichnung	Description		200		225		250		280		315		
			2 Pol	4-8 Pol	2 Pol	4-8 Pol	2 Pol	4-8 Pol	2 Pol	4-8 Pol	2 Pol	4-8 Pol	
1	Lagerschild AS (DE)	palier roulement AS (côté A)	A.N°	140200	140220	140240	140260	140280	140300	140320			
			Preis	419.20	585.50	645.35	844.95	844.95					
2	Flansch B5	flasque B5	A.N°	140201	140221	140241	140261	140281	140301	140321			
			Preis	871.60	951.40	1'343.90	1'530.20	2'115.65					
3	Lagerdeckel innen AS (DE)	couvercle roulement intérieur AS	A.N°	140202	140222	140242	140262	140282	140302	140322			
			Preis	153.10	153.10	153.10	153.10	153.10					
4 4a	Lagerdeckel aussen AS (DE)	couvercle roulement extérieur AS (DE)	A.N°	140203	140223	140243	140263	140283	140303	140323			
			Preis	153.10	153.10	153.10	193.00	193.00					
5	Lagerdeckel innen GS (NDE)	couvercle roulement intérieur GS	A.N°	140204	140224	140244	140264	140284	140304	140324			
			Preis	153.10	153.10	153.10	153.10	153.10					
6	Lagerschild GS (NDE)	palier roulement GS (côté B)	A.N°	140205	140225	140245	140265	140285	140305	140325			
			Preis	419.15	585.50	645.35	844.95	844.95					
7	Lagerdeckel aussen GS	couvercle roulement extérieur GS	A.N°	140206	140226	140246	140266	140286	140306	140326			
			Preis	153.10	153.10	153.10	193.00	193.00					
8	Haube	capot	A.N°	140207	140227	140247	140267	140287	140307	140327			
			Preis	286.05	346.40	379.20	459.10	472.35					
9	Ventilatorflügel	ventilateur	A.N°	140208	140209	140228	140229	140248	140249	140268	140288	140308	140328
			Preis	259.45	259.45	266.10	266.10	266.10	266.10				
10	Klemmenkasten	boîte à bornes	A.N°	140210	140230	140250	140269	140289	140309	140329			
			Preis	346.00	346.00	485.70	485.70	485.70	884.85				

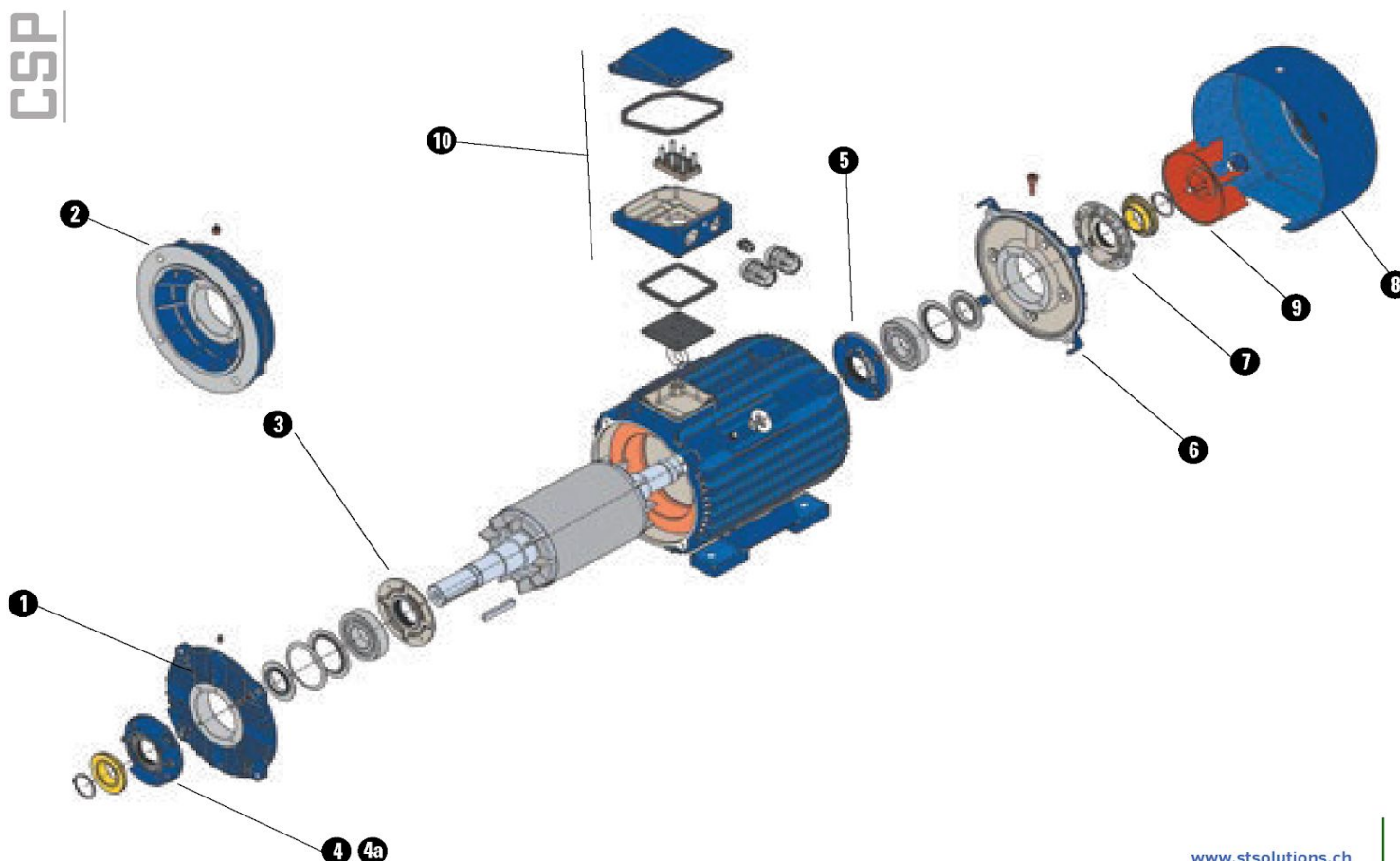

- Bei Ausführungen "z" Multifuss, kann der Klemmenkasten versetzt werden. Oben, rechts oder links.
- Ab Baugrösse 200 - 315, ist der Klemmenkasten auf Anfrage rechts oder links erhältlich. (Rechts ab Lager).
- Baugrösse 132 auf Anfrage in Aluminium.
- Auf Anfrage mit **AGRO**-Messingverschraubungen.
- Les moteurs en version "z" multipied, la position de la boîte à bornes est possible à droite et à gauche.
- De la grandeurs 200 - 315, la position de la boîte à bornes est disponible sur demande à gauche ou à droite. (droite en stock).
- Grandeur 132, sur demande en aluminium.
- Sur demande avec des raccords presse étoupe en laiton nickelé **AGRO**.

Typ	Klemmenkasten	Kabeleinführung	Kabelverschraubung	Gehäuse	Füsse	Lagerschild	Flansch
	Boîte à bornes	Entrée de câble	Presse-étoupe	Carcasse	Pied	Paliers	Flasque
56	oben / dessus	1x 180°	1x M20 x1.5	Aluminium / aluminium			
63	oben / dessus	1x 180°	1x M20 x1.5				
71	oben / dessus	1x 180°	1x M20 x1.5				
80	oben / dessus	1x 180°	1x M20 x1.5				
80 z	multi / multi	4x 90°	1x M20 x1.5				
90	multi / multi	4x 90°	1x M20 x1.5				
100	multi / multi	4x 90°	1x M20 x1.5				
112	multi / multi	4x 90°	1x M25 x1.5				
132	oben / dessus	1x 180°	1x M25 x1.5				
132 z	multi / multi	4x 90°	1x M25 x1.5				
160	oben / dessus	1x 180°	1x M40 x1.5				
160 z	multi / multi	4x 90°	1x M40 x1.5				
180	oben / dessus	1x 180°	1x M40 x1.5				
180 z	multi / multi	4x 90°	1x M40 x1.5				
200	oben / dessus	4x 90°	2x M50 x1.5 / 1x M16 x1.5				
225	oben / dessus	4x 90°	2x M50 x1.5 / 1x M16 x1.5				
250	oben / dessus	4x 90°	2x M63 x1.5 / 1x M16 x1.5				
280	oben / dessus	4x 90°	2x M63 x1.5 / 1x M16 x1.5	Grauguss / fonte			
315	oben / dessus	4x 90°	2x M76 x3.0 / 1x M16 x1.5				



Zulässige radiale und axiale Belastung:

Zulässige radiale und axiale Belastungen auf der Welle bei horizontaler und vertikaler Montage.

Radialbelastungswerte sind auf einer Grundlage und einer Lebensdauer von 20'000 - 25'000 Stunden (bei max. 40°C) und einer Frequenz von 50 Hz berechnet worden. Beim Betrieb mit 60 Hz müssen die Werte [N] um 6-10% gesenkt werden, um die gleiche Lebensdauer zu erhalten.

Charge radiale et axiale autorisée:

Charge radiale et axiale autorisée sur l'arbre moteur pour un montage horizontal et vertical.

Les valeurs de charge radiale sont calculées sur une base d'utilisation et de durée de vie de 20'000-25'000 heures (température max. 40°C) et une fréquence réseau de 50Hz. Pour une utilisation avec une fréquence réseau de 60Hz la valeur [N] doit être réduite de 6 à 10% pour une durée de fonctionnement identique.

$$F_R = \frac{19600 \times P \times k}{D_k \times n} \text{ N}$$

Wert der Radialkraft F_R , die auf die Motorwelle bei bestimmtem Durchmesser der Riemenscheibe wirkt, wird mittels folgender Formel berechnet:

La valeur de la force radiale F_R , appliquée sur l'arbre moteur, pour un diamètre de poulie définie, sera calculée selon la formule suivante :

$$F_R = F_{X0} \frac{X}{E} \times (F_{X0} - F_{Xmax}) \text{ [N]}$$

Wert der F_{X0} - Kraft, die auf einem beliebigen Punkt des Wellenendes (zwischen Punkten $X=max.$ und $X=0$) wirkt, wird mittels folgender Formel berechnet:

La valeur de la force radiale F_R appliquée en un point arbitraire sur l'arbre moteur, sera calculée selon la formule suivante :

- FR** [N] = maximale Radialbelastung
- M** [Nm] = Drehmoment
- n** [min-1] = Nennzahl des Motors
- k** [-] = Vorspannfaktoren in Funktion der Riemenscheibe.
Die folgenden Faktoren müssen beachtet werden:
k = 2,2 Für Keilriemen; k = 3 Für normale Flachriemen;
- F** [N] = Riemenzug
- P** [kW] = Nennleistung Motor
- D_k** [m] = Durchmesser der Riemenscheibe
- E** = Länge Wellenende
- FX0** = Wert der F_R -Kraft, die am Anfang des Wellendens wirkt
- FX max** = Wert der F_R -Kraft, die am Ende des Wellendens wirkt

- FR** [N] = Charge radiale maximum
- M** [Nm] = Couple
- n** [min-1] = Vitesse nominale du moteurs
- k** [-] = Facteur de précharge en fonction de la poulie.
Les facteurs suivants sont à appliquer:
k= 2.2 pour courroie de ventilateur, k = 3 pour courroie plate
- F** [N] = force de tension de la courroie
- P** [kW] = Puissance nominale du moteur
- D_k** [m] = Diamètre de la poulie
- E** = Longueur de l'extrémité de l'arbre
- FX0** = Valeur de la force F_R , qui au début de la sortie d'arbre sera appliquée
- FX max** = Valeur de la force F_R , qui à la de la sortie d'arbre sera appliquée

Radialbelastung / charge radiale
IM B3; IM B5

Axialbelastung / charge axiale
IM B3; IM B5

Axialbelastung / charge axiale
IM V5; IM V1

Axialbelastung / charge axiale
IM V6; IM V3

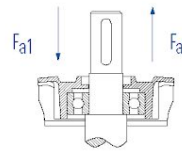
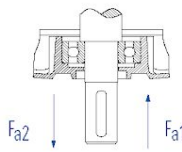
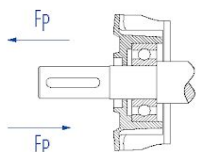
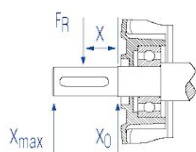

Typ	2 Pol				
	FR (x=0)	FR (x=max)	FP	Fa1	Fa2
	[N]				

56	200	160	40	30	50
63	200	160	40	40	60
71	290	240	70	50	90
80	330	270	90	60	120
90	680	440	680	350	380
100	880	460	900	280	400
112	1000	480	1000	400	450
132	1820	660	1900	430	600
160	2200	980	2300	920	950
180	2920	1300	3000	1100	1200

200	L					
	LA	2910	2440	2240	1720	2920
	LB	2850	2390	2230	1670	2930

225	S				
	M	3310	2810	2530	1930

250		4090	3390	3110	2330	4130
------------	--	------	------	------	------	------

280	S	3940	3340	3070	2010	4430
	M	3800	3220	3030	1890	4490

315	S	3560	3080	2960	1630	4690
	MA	3070	2650	2820	1230	4890
	MB	2670	2310	2710	910	5050
	MC	2840	2480	2710	630	5370

MD					
-----------	--	--	--	--	--

Typ	4 Pol				
	FR (x=0)	FR (x=max)	FP	Fa1	Fa2
	[N]				

	250	200	50	40	60
	250	200	60	50	70
	360	300	90	70	110
	440	370	120	90	150
	780	440	780	350	380
	1060	460	980	380	400
	1450	480	1400	400	450
	2100	660	220	450	600
	2400	980	2400	920	950
	3600	1300	3600	1100	1300
	3610	3030	2810	2120	3700

	4180	3400	3190	2420	4160
	3970	3230	3130	2260	4240
	4900	4060	3850	2680	5360
	6690	5670	5010	3650	6770
	6150	5220	4860	3160	7040
	5750	4820	4740	2710	7370
	5400	4520	4640	2410	7530
	5160	4330	4580	2200	7640
	6270	5330	4340	1460	8060

Typ	6 Pol				
	FR (x=0)	FR (x=max)	FP	Fa1	Fa2
	[N]				

	250	200	60	50	70
	270	220	60	50	70
	400	350	100	80	120
	510	420	140	110	170
	960	440	960	350	380
	1200	460	1100	380	400
	1620	480	1600	400	450
	2800	660	2800	500	600
	2850	1100	2900	980	1000
	4000	1800	4100	1400	1700

	4310	3620	3620	2920	4560
	4060	3400	3540	2710	4650

	4570	3720	3980	2950	5330
	5920	4900	4990	3810	6550
	7860	6670	5790	4320	7700
	7690	6520	5750	4190	7750
	7210	6040	5610	3840	8140
	6750	5660	5480	3220	8400
	6270	5330	5340	2680	8780
	7570	6440	5080	1870	9230
	7470	6360	5050	1820	9220

Masse Motoren IEC 56-315 (Richtwerte) / Dimensions moteurs (valeur indicative)

B3

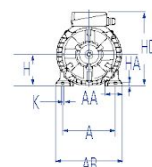

IEC	56	63	71	80	90	100	112	132	160	180	200	225	250	280	315	
A	90	100	112	125	140	160	190	216	254	279	318	356	406	457	508	
B	71	80	90	100	100	140	140	140	210	241	305	286	349	368	406	
B1	-	-	-	-	125	-	-	178	254	279	-	311	-	419	457	
C	36	40	45	50	56	63	70	89	108	121	133	149	168	190	216	
D 2 Pol 4-6 Pol	9 11	14 19	24 28	28 38	42 48	55 60	65 75	80	110	110	110	110 140	140 140	140 140	140 170	
E 2 Pol 4-6 Pol	20 23	30 40	50 60	60 80	110 110	110 110	110 110	110 110	110 110	110 110	110 110	110 140	140 140	140 140	140 170	
F 2 Pol 4-6 Pol	3h9 4h9	5h9 6h9	8h9 8h9	10h9 12h9	14h9 14h9	16 16	18 18	18 20	18 22	18 22	18 22	16 18	18 20	18 22	18 22	
GA 2 Pol 4-6 Pol	10.2 12.5	16 21.5	27 31	31 41	45 51.5	59 59	64 64	69 69	69 79.5	69 85	69 85	59 64	64 69	69 79.5	69 85	
H	56	63	71	80	90	100	112	132	160	180	200	225	250	280	315	
HA	7	8.5	8	9	10	12	14	18	25	27	32	34	37	40	48	
HB	98	102	111	120	130	140	164	197	223	228	320	345	385	440	490	
K	5.8	7	7	10	10	12	12	12	15	15	19	19	24	24	28	
AA	30	36	45	55	47	52	52	61	81	92	80	85	90	105	135	
AB	110	124	142	160	182	202	222	266	320	353	400	440	480	550	610	
BB	92	106	116	130	153	170	170	220	300	320	380	380	445	520	600	
HD	154	165	182	199	238	257	280	329	383	414	520	570	635	720	805	
L	A2 A4	A2 A4 A6	A2 A4 A6	A2 A4 A6	S2 S4 S6	L2 L6	M2 M6	SA2 SB2 S4 M4 S6 MB6	MA2 MB2 L2 M4 L4 L6	M2 M4 L4 L6	LA2 LB2 L4 LA6 LB6	M2 S4 M4 M6	M2 S4 M4 M6	M2 S4 M4 M6	M2 S4 M4 M6	S2 MA2; MB2 1235 S4; MA4 1265 MC2; MC4; MC6; MD6 1320 MB6
	183	200	223	266				512				1010				
	B2 B4	B2 B4 B6	B2 B4 B6	B2 B4 B6	L2											
	193	210	223	278	331	377	398									
	XC2 XC4	XC2 XC4 XC6	XC2 XC4 XC6	XC2 XC4 XC6	L4 L6	LA4 LB4	M4									
	204	228	263	306	356	417	425	542	643	723	850	930	1040	1135	1355	

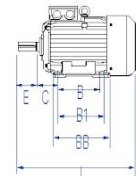

WE

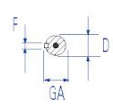

B5

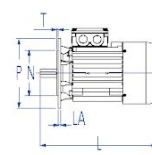

B5 56-200

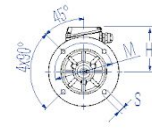

B5 225-315



B14-1

Flansch - B5 / Bride B5

N	M	P	LA	T	S
80	100	120	8	3	7
95	115	140	9	3	10
110	130	160	9	3.5	10
130	165	200	10	3.5	12
130	165	200	8	3.5	12
180	215	250	11	4	15
180	215	250	12	4	15
230	265	300	12	4	15
250	300	350	13	5	19
250	300	350	13	5	19
300	350	400	16.5	5	19
350	400	450	18	5	19
450	500	550	23	5	19
450	500	550	23	5	19
550	600	660	23	5	19
660	600	660	23	5	19

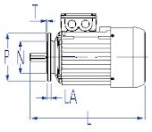

Flansch - B14-1 (B5R) / Bride B14-1 (B5R)

N	M	P	LA	T	S
70	85	105	15	2.5	M6
80	100	120	14	3	M6
95	115	140	14	3	M8
110	130	160	14	3.5	M8
110	130	160	10	3.5	M8
130	165	200	12	3.5	M10
130	165	200	12	3.5	M10
180	215	250	12	4	M12
230	265	300	12	4	M12

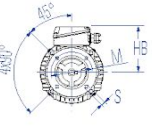

B14-2

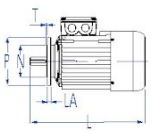

Flansch - B14-2 / Bride B14-2

N	M	P	LA	T	S
50	65	80	12.5	2.5	M5
60	75	90	9.5	2.5	M5
70	85	105	12	2.5	M6
80	100	120	12	3	M6
95	115	140	10	3	M8
110	130	160	12	3.5	M8
110	130	160	12	3.5	M8
130	165	200	12	3.5	M10

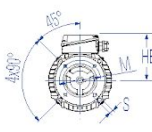

Roulements des moteurs

Typ	Pol	A-Seite (AS)	G-Seite (GS)	Optional / en options		
				mit Nachschmierung		Festlager
				A-Seite (AS)	G-Seite (GS)	A- / G-Seite
56	2-6	6201 2RS C3	6201 2RS C3	-	-	-
63	2-6	6202 2RS C3	6202 2RS C3	-	-	-
71	2-6	6203 2RS C3	6203 2RS C3	-	-	•
80	2-6	6204 2RS C3	6204 2RS C3	-	-	•
90	2-6	6205 2Z C3	6205 2Z C3	-	-	•
100	2-6	6206 2Z C3	6206 2Z C3	-	-	•
112	2-6	6306 2Z C3	6306 2Z C3	-	-	•
132	2-6	6308 2Z C3	6308 2Z C3	• 6308 C3	• 6308 C3	•
160	2-6	6309 2Z C3	6309 2Z C3	• 6309 C3	• 6309 C3	•
180	2-6	6311 2Z C3	6311 2Z C3	• 6311 C3	• 6311 C3	•

Typ	Pol	A-Seite (AS)	G-Seite (GS)	Optional / en options		
				Rollenlager	Isolierte Lager	Nachschmierung
200	2-6	6312 C3	6312 C3	• NU 312 C3	• 6312 C3 VL0241	#
225	2-6	6313 C3	6313 C3	• NU 313 C3	• 6313 C3 VL0241	#
250	2-6	6315 C3	6315 C3	• NU 315 C3	• 6315 C3 VL0241	#
280	2	6315 C3	6315 C3	• NU 315 C3	• 6315 C3 VL0241	#
	4-6	6318 C3	6318 C3	• NU 318 C3	• 6318 C3 VL0241	#
315	2	6315 C3	6315 C3	• NU 315 C3	• 6315 C3 VL0241	#
	4-6	6318 C3	6318 C3	• NU 318 C3	• 6318 C3 VL0241	#
315 MC / MD	4-6	6320 C3	6318 C3	• NU 320 C3	• 6320 C3 VL0241	#

= Standard / • = auf Anfrage / - = nicht erhältlich
= standard / • = sur demande / - = indisponible

Einbaulagen nach IEC 34-7

Formes de montage selon IEC 34-7

Fuss Montage / montage à pied					
IM 1001 (B3)	IM 1051 (B6)	IM 1061 (B7)	IM 1071 (B8)	IM 1011 (V5)	IM 1031 (V6)
Flansch Montage / montage à bride					
IM 3001 (B5)	IM 3011 (V1)	IM 3031 (V3)	IM 3601 (IM B14)	IM 3611 (V18)	IM 3631 (V19)
Fuss-Flansch Montage / montage à pied-bride					
IM 2001 (B3B5)	IM 2011 (V15)	IM 2031 (V36)	IM 2101 (B34)	IM 2111 (V58)	IM 2131 (V69)



ST Solutions SARL
Rue du Parc 17, 1400 Yverdon-Les-Bains
+41245551515

